

# MEDALLION PROFESSIONAL

## 34" HOT TOP/OPEN BURNER TOP COMBINATION RANGE WITH OVEN

### STANDARD FEATURES

- Stainless steel front and sides STANDARD
- 6" (152mm) chrome steel adjustable legs
- Adjustable stainless steel front rail 6-1/16" (154mm) to 7-5/8" (194mm)
- 17" (432mm) Hot Top Section-One (1), 40,000 BTU (11.72 kW), "H-Type" Cast-Iron
- Piezo spark ignition for oven, and a porcelainized oven interior
- 1-1/4" NPT front manifold
- 40,000 BTU, (11.72 kW), cast iron oven burner: 30,000 BTU (8.8kW), tubular shaped aluminized steel Convection Oven burner
- Oven Thermostat (temp range: 150°F to 500°F)
- Storage base interior is aluminized steel
- One year limited parts & labor warranty (USA and Canada only)

### OPTIONAL FEATURES

- Stainless steel back rear panel
- Stainless steel common front rail up to 68" (1728mm) wide, (No additional charge)
- Stainless steel oven interior
- Additional oven rack
- Rear gas connection, on select models 3/4" or 1" NPT
- End caps and cover (no charge)- Must specify
- Polyurethane non-marking swivel casters (2) w/front brakes
- Toe base (not for use with "C" oven base)
- Storage base shelf-aluminized or stainless steel
- Single deck stainless steel high shelf
- Double deck stainless steel high shelf
- 10" (254 mm), 17" (432mm) 22.375" (568mm) 34.375" (873mm) high stainless steel backguard
- Stainless steel vertical flue riser, 13"W x 34.375"H, (330mm x 873mm)

# AMERICAN RANGE

CHEF INSPIRED, PROFESSIONAL COOKING EQUIPMENT



Engineered 4 Excellence



Model Shown HD34-IHT-2-1

Shown with optional background



Engineered 4 Excellence

### SHORT FORM SPECIFICATIONS:

The Medallion Professional E4E (Engineered 4 Excellence) Heavy-Duty Series by American Range is the crème de la crème in commercial cooking equipment. Designed for the professional chef in high demanding/continuous use operations. Our Medallion Professional E4E Series offers advanced innovation and technology to deliver unprecedented cooking performance and experience.

Model: **HD34-IHT-2-1**, Heavy-Duty Medallion Professional E4E, gas powered **34" Hot Top/Open Burner Top Combination Attachment with Oven**. Includes stainless steel front and sides with 6" chrome legs (unless otherwise specified). One (1) 17" wide x 7/8" thick Hot Top section. One (1) **Power-Max** 40,000 Btu/hr. cast iron H-Type burner on the Hot Top and Two (2) **Power-Max** 37,000 Btu/hr. Lift-Off open burners. Total 114,000 Btu's/hr. on cooking surface. Unit to be 34" (864mm) wide and 38" (965mm) deep with telescoping front rail fully extended to a maximum of 7-5/8" (194mm). Oven interior to be porcelain enameled measuring 26-1/4" (667mm) W x 27-1/4" D x 14 1/4" H. with **Power-Max** 40,000 Btu/hr. cast iron standard oven burner. Convection oven option measuring 23" (584mm) D. and a tubular shaped aluminized steel **Power-Max** 30,000 Btu/hr. convection oven burner. Specify Natural gas (NG) or Liquid Propane gas (LP), ETL listed. Available options include Convection Oven—Model: HD34-IHT-2-1C, Storage Base with removable hinged double doors—Model: HD34-IHT-2-0, or as a Modular Top—Model: HD34-IHT-2-M.

## 34" HOT TOP/OPEN BURNER TOP COMBINATION RANGE WITH OVEN

With standard oven, convection oven, storage base, or modular top  
HD34-IHT2-I, HD34-IHT2-IC, HD34-IHT2-0, HD34-IHT2-M

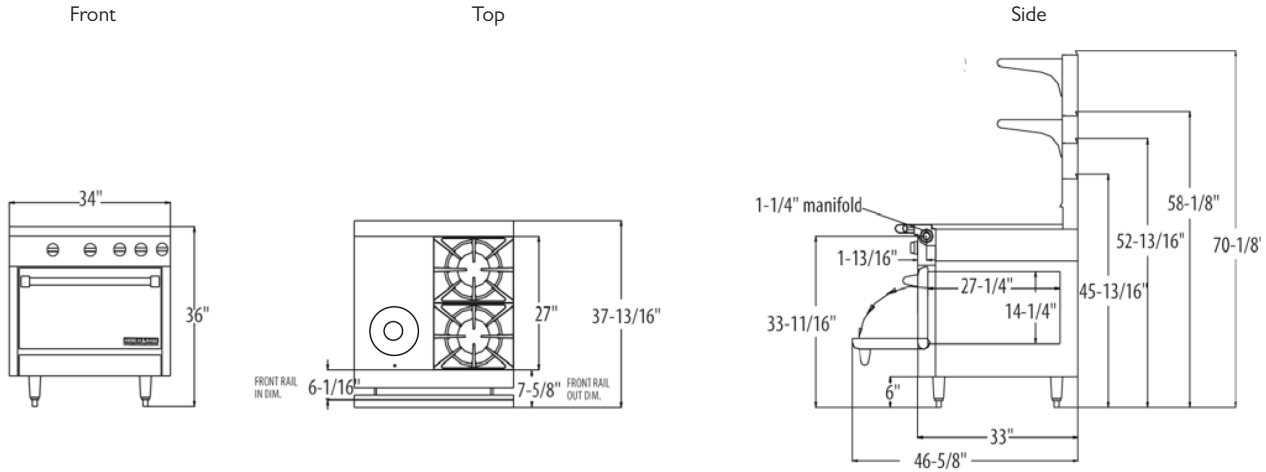

### EXTERIOR DIMENSIONS

Model#	HD34-IHT2-I (C)	HD34-IHT2-0	HD34-IHT2-M
Width	34"/864mm	34"/864mm	34"/864mm
Depth	38"/965mm (Rail out Dim)	38"/965mm (Rail out dim)	38"/965mm
Height w/NSF legs	36"/914mm	36"/914mm	36"/914mm(w/stand)
Height Less NSF Legs	30"/762mm	30"/762mm	8"/203mm (less stand)

### STORAGE OVEN/CONVECTION OVEN/STORAGE BASE INTERIOR NOTE: 34-IHT-M IS 9 1/2"/241MM HIGH

	HD34-IHT2-I	HD34-IHT2-0	HD34-IHT2-M
Width	26 1/4"/667mm	30 1/2"/775mm	N/A
Depth	27 1/4"/692mm**	30"/762mm	N/A
Height	14 1/4"/362 mm	20"/508mm	N/A
Weight (LB/KG)	490/222	480/218	260/118

\*\* (C) Oven is 23" (584 mm) Deep

INPUT-Btu/hr (N-Gas)	HD34-IHT2-I	kW Equivalent	HD34-IHT2-0	KW Eq	HD34-IHT2-M	kW Equivalent
O/T Burner	114,000	33.40	114,000	33.40	114,000	33.40
(37,000BTU/ea)	40,000	11.72	N/A	—	N/A	—
TOTAL	154,000	45.12	114,000	33.40	114,000	33.40

I = Oven / C=Convection Oven (30,000BTU/ea) / 0= Storage Base / M= Modular Top

#### Installation Notes:

Combustible Wall Clearances

Sides: 6" (152mm)

Back: 6" (152mm)

For reduced clearances, refer to ANSI Z223.1/NFPA #54 and CAN/CGA B149.

#### Entry Clearance:

Crated: 39-1/4" (997mm)

Uncrated: 34-1/4" (870mm)

#### Manifold Pressure:

Natural 6 W.C. (15 mbar)

Propane 10 W.C. (25 mbar)

NOTE: Data applies only to North America.

Gas Input Ratings shown here are for installations up to 2,000 ft. (610m) above sea level. Specify altitudes over 2,000 ft.

Gas Input Ratings shown here are for installations up to 2,000 ft. (610m) above sea level. Specify altitudes over 2,000 ft.

Commercial cooking equipment requires an adequate ventilation system. For additional information, refer to the National Fire Protection Association's standard NFPA96 "Vapor Removal from Cooking Equipment." (NOTE: For North America only)

Please specify gas type when ordering.



Because of continuing product improvement these specifications are subject to change without notice.